

Depend on Davey

DAVEY

APPLICATIONS

Ideal for swimming pool applications such as:

- Filtration
- Suction & in-floor pool cleaning system
- Backwashing
- Water features
- Spa jet operation
- Solar pool heating
- Gas and heat pump spa & pool heating

WHY CHOOSE THE INNOVATIVE ProMaster® VSD ECO Series pump?

Fully Variable Speed Control - The ProMaster® offers the pool owner and operator total control over the speed at which the pump needs to operate, from 1,500rpm to 3,600rpm.

Super Quiet - Designed with a unique water-cooled motor which captures noise and vibrations, allowing super-quiet operation, rated down to 50 dBA. Your neighbours won't even know it's there.

Backwash Function - ProMaster® is designed with a selectable backwash cycle that runs the pump for 2 minutes at 3,800rpm before shutting down. It provides for safe, reliable and easy operation of the pump when backwashing your media filter.

Dependable - ProMaster® incorporates unique loss of prime protection to minimise pump damage if no water is available to the pump.

Convenient - By water-cooling the motor, ProMaster® does not require air ventilation, and gives installers more flexibility with pump positioning.

- Easy to install set and operate, no complicated digital push button controls
- Automatic restart technology
- Large 4.5 litre leaf basket for long intervals between cleaning
- Over temperature derating, pump will automatically slow down in high ambient temperatures

Energy Efficiency - 8 Star energy rating offering up to 70% lower energy use than a traditional fixed speed 1hp pump.



NEW



DAVEY
ProMaster®

Super Quiet Innovative Pool Pump

Davey's ProMaster® Variable Speed pool pump offers water-cooled, super-quiet operation with high efficiency, making it the ideal choice for today's swimming pools.



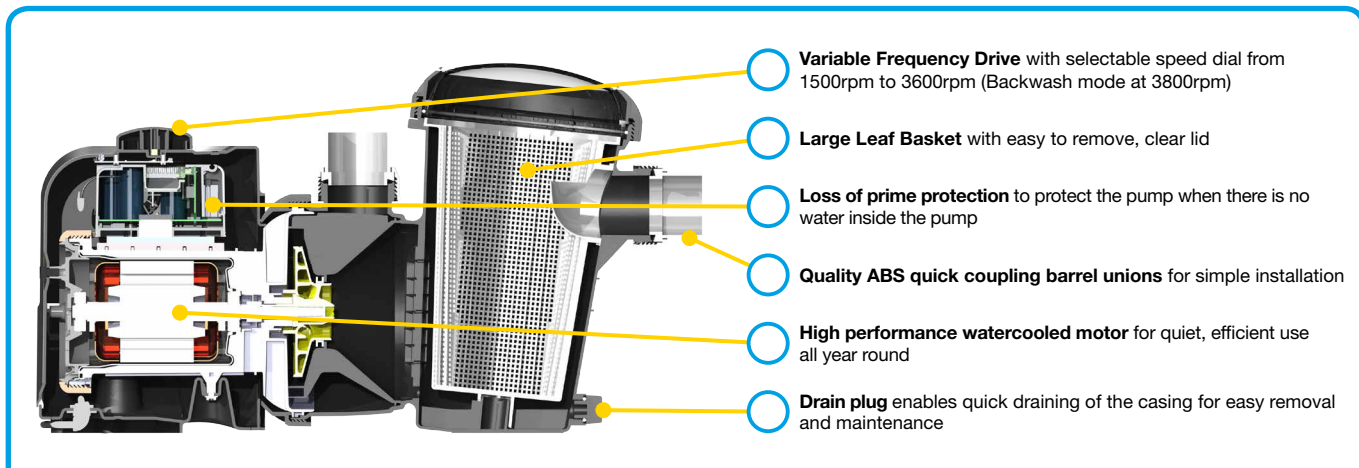

ELECTRICAL DATA	
Model	PM200SV
Voltage (V)	240
Supply Frequency (Hz)	50
Motor Input Power (W/hp)	116W/0.16hp @ Dial 1 488W/0.65hp @ Dial 5 1000W/1.34hp @ Dial 10 1316W/1.76hp @ Backwash
Motor Speed (rpm)	1500 to 3600
Backwash (rpm)	3800
Enclosure Class (IP)	45
Insulation Class	F
Lead Length	3m

OPERATING LIMITS	
Max. water temperature	40°C
Max. ambient temperature	50°C
Noise level (AS 5102.2)	50 dBa*

*At Speed 1.

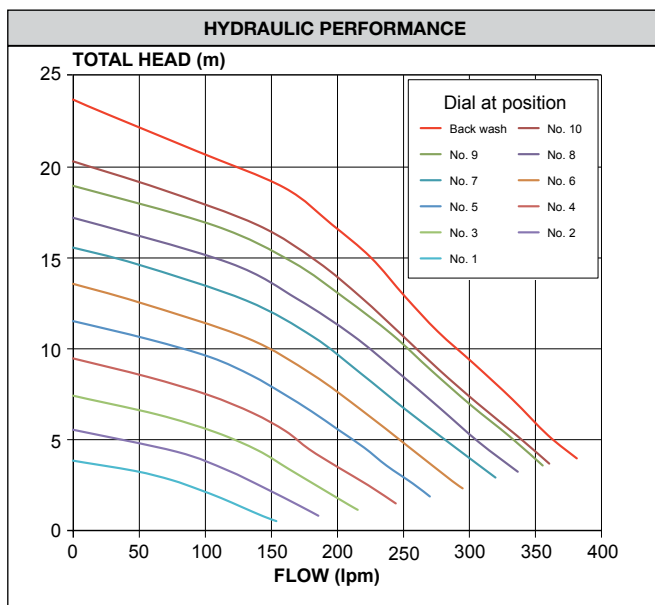

DIMENSIONS (mm)												
Model	A	B	C	D	E	F	G	H	I	Mounting Holes Diameter	Inlet/Outlet PVC	Net Weight (kg)
PM200SV	305	670	320	350	65	230	380	200	250	10	40/50	14

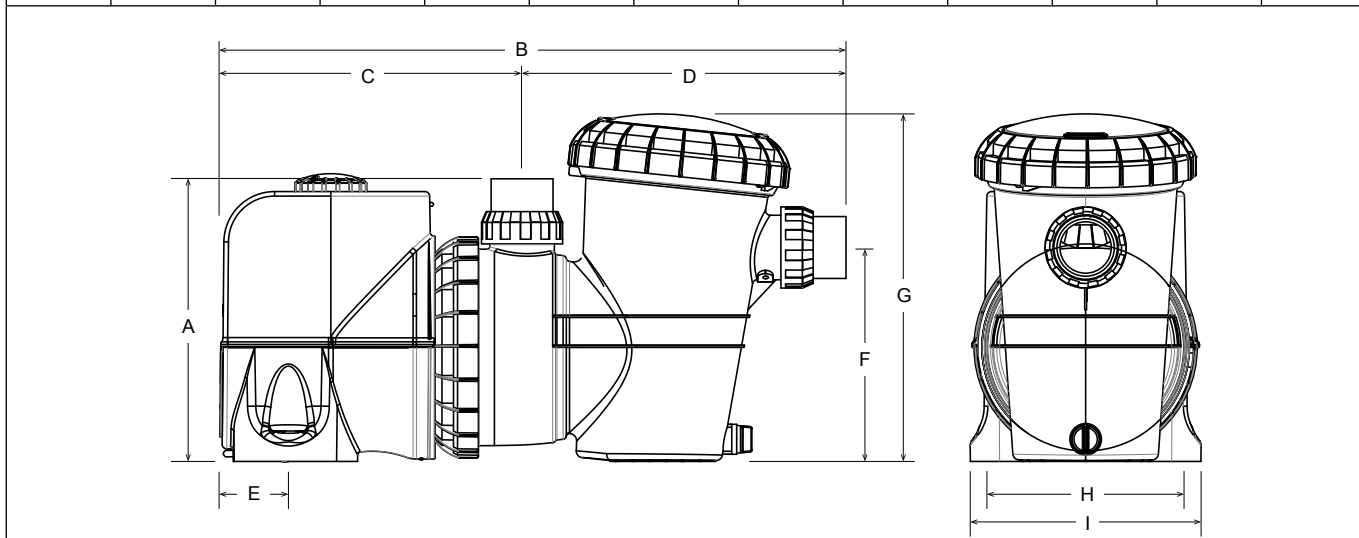

davey.com.au | daveynz.co.nz | daveyeurope.eu | daveypoolusa.com

This literature is not a complete guide to product usage. Further information is available from your Davey Dealer, Davey Support Centre and from the relevant product Installation and Operating Instructions. Must be read in conjunction with the relevant product Installation and Operating Instructions and all applicable statutory requirements. Product specifications may change without notice.
© Davey is a registered trademark of Davey Water Products Pty Ltd. © Davey Water Products Pty Ltd 2015.